

Technical Specification :

- 1.Design and manufacture: ASME B16.34
- 2.Face-to-face : ASME B16.10.
3. Inspection and test : API598
- 4.End flange:ASME B16.5

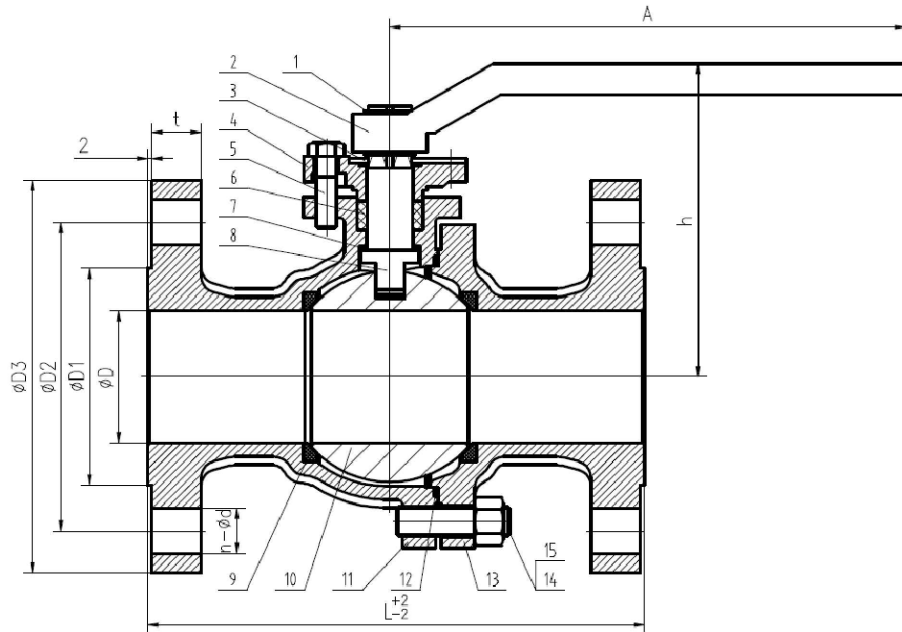

SIZE	DN	L	H	D	A	D1	D2	D3	t	n-Ød
1/2"	15	140	71	15	145	34.9	66.7	95	12.7	4-Ø15.9
3/4"	20	152	71	20	145	42.9	82.6	115	14.3	4-Ø19
1"	25	165	90	25	175	50.8	88.9	125	15.9	4-Ø19
1 1/4"	32	178	95	32	175	63.5	98.4	135	17.5	4-Ø19
1 1/2"	40	190	128	38	250	73	114.5	155	19.1	4-Ø22
2"	50	216	142	50	250	92.1	127	165	20.7	8-Ø19
3"	80	282	178	78	305	127	168.3	210	28.6	8-Ø22.3

Main Technical Parameter

Nominal pressure		300LB	MPa
Test Pressure	Strength test	7.5	
	Seal test	5.5	
	Air seal test	0.4~0.7	
Applicable temperature		-29~150°C	
Applicable medium		Water, Oil, Gas	

MAIN PARTS AND MATERIALS

NO	Part name	Material	QTY	NO	Part name	Material	QTY			
1	Ring	65Mn	2	9	Seat	RPTFE	2			
2	Handle	CF8	1	10	Ball	304/316	1			
3	Locking cover	304	1	11	Body	CF8/CF8M	1			
4	Packing Gland	CF8	1	12	Seal	RPTFE	1			
5	Hexagon nut	304	2	13	Cap	CF8/CF8M	1			
6	Packing	RPTFE	1	14	Nut	304	6			
7	Thrust Washer	RPTFE	1	15	Hexagon bolt	304	6			
8	Stem	304/316	1	16						
				图样标记				重量	单位	比例
								mm	1:1	
				参考标准						
				名称				2PC high mounting pad Ball Valve		
标记 处数 更改文件号 签字 日期										
设计				审核				青岛英利机械有限公司 QINGDAO YINGLI MACHINERY CO.,LTD		
校对				标准化						
工艺				批准						
画法				日期						
				共				页	第	页